

Introduction

You need phase measurements to set up and verify electronic devices in amplifiers and in audio, control, ultrasound, and echo systems. Phase measurements can be problematic, because not many simple, inexpensive phase meters are available. Moreover, using an oscilloscope is time consuming and imprecise. The phase meter described here uses a standard voltmeter as an output device. It measures the phase difference between two signals with better than 1% accuracy and it operates to 10MHz. It's inexpensive to build, and it's simple to calibrate.

Measuring phase involves converting two periodic signals to square waves, then measuring the phase difference between the two square waves. If the amplitude of both square waves is identical and constant, the average of the time difference between the square waves is proportional to the phase shift. Usually the value you wish to measure is the phase shift between the input of a circuit under test (called the "reference") and the output of the circuit (called the "signal"). But, these signals may have different amplitudes. The amplitude differences affect the slew rate of the analog signals. The differing slew rates may result in a phase error if the squaring mechanism is not perfect.

In Figure 1, IC₁ (an HA5024) is configured as a switched-gain amplifier that has four gain selections. IC₁ can, thus, make the reference and signal amplitudes nearly equal, thereby minimizing slew-rate errors. This design switches amplifiers rather than resistor-feedback networks, so you can optimize each amplifier for bandwidth, overshoot, and propagation delay. The propagation delay of IC₁ introduces a phase-measurement error that has the same magnitude as the error arising from the propagation delay of IC₂. Because the two op amps have identical schematics and undergo the same IC processing, their propagation delays match closely, thus, canceling any propagation-delay errors.

After undergoing amplification by IC₁ and IC₂, the reference and signal go to IC₃ (an HFA3102), a matched set of long-tailed pairs that function as matched, high-speed comparators. The bases of the reference transistors in the comparators connect to ground, so the input signals must use a ground reference. If the bases are not grounded, it's easy to reference symmetrical inputs to ground by coupling them through a capacitor. Clamp diodes D₁ through D₄ protect the input bases. R₁₈ and R₁₉ bias the current sources at -2.2V, and R₁₆ and R₁₇ set the comparator currents at 10mA, so the transistors operate at their maximum f_T.

The value of R₂₃ ensures that the collector voltage drop is greater than 5V (to ensure that D₆ turns on). The output-signal swing is constant at $V_{OS} = V_{+5} - V_{D5} - V_{D6}$. Because the input signals have approximately the same amplitude, the comparators are matched, the output-voltage swing is constant, and the HFA3102 has a 10-GHz f_T. The only variable is phase. When the inputs are in phase (phase shift = 0°), the average collector voltage is 0V. When the inputs are 90° out of phase, the average collector voltage is $V_{OS}/4$. When the inputs are 180° out of phase, the average collector voltage is $V_{OS}/2$. The relationship is linear, so it indicates phase shift as a function of the average collector voltage. You need to effect level shifting and an offset null to compensate for initial errors.

The divider comprising R₂₄, R₂₅, and R₂₆, reduces the average collector voltage from the matched comparators by a factor of two. R₂₆ is a gain, or span, adjustment, and C₁ functions as an integrator that yields the average value of the voltage developed across the divider network. IC₄ (an HA5170) has low input current, so it won't discharge C₁. IC₄ buffers C₁ and presents a low-impedance output. R₂₉ provides an offset adjustment you use to set the zero-phase voltage. To calibrate the phase meter, first set the signal to 0° phase shift, adjust R₂₉ for 0V, then set the phase shift to 180° and adjust R₂₆ for 1.8V. The output scale factor is, thus, 10mV/degree. You may have to iterate the adjustments to obtain 1% accuracy. The PC board is critical in this design: Use a ground plane, keep trace lengths and component leads short, and use good components.

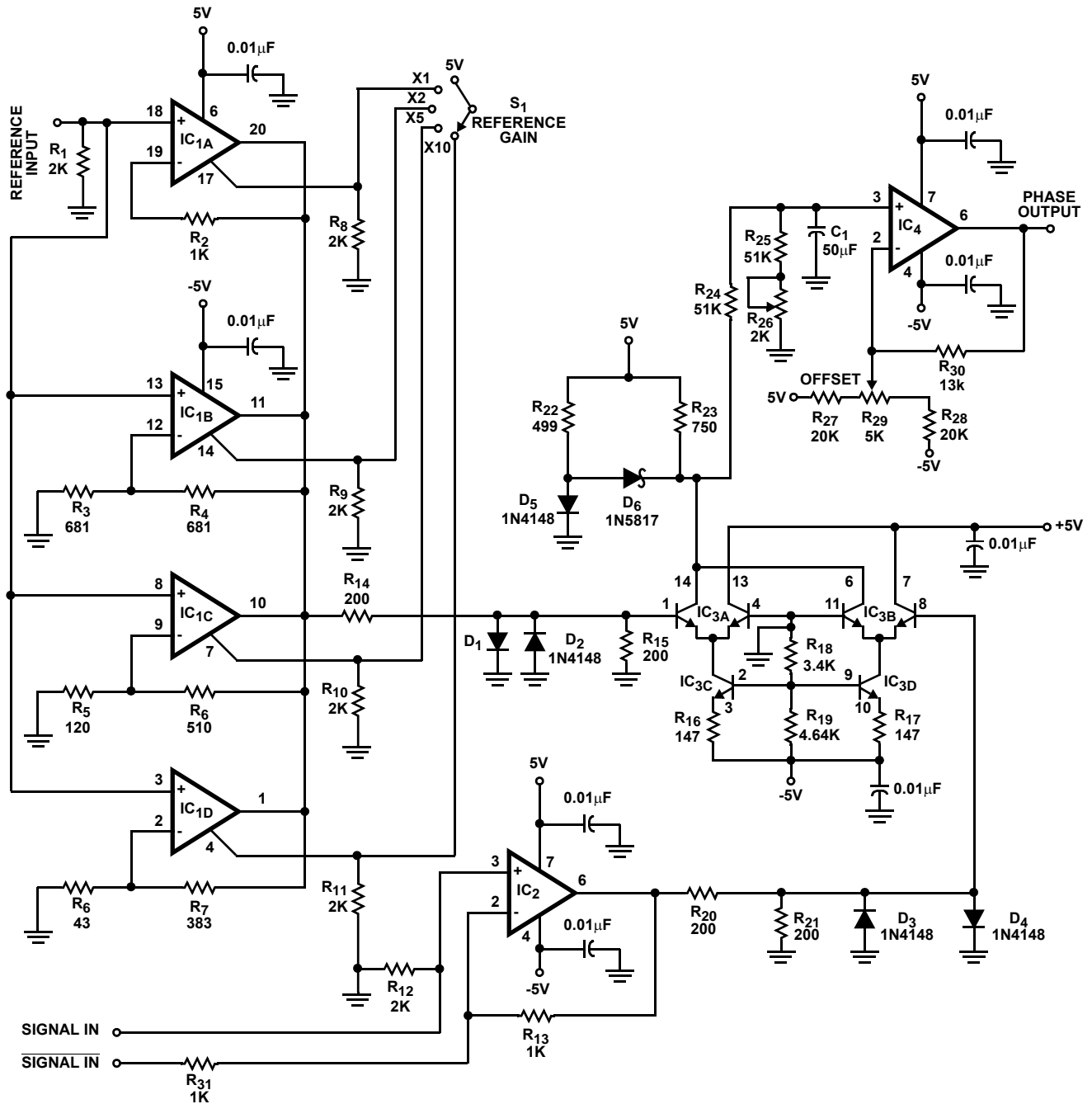

NOTES:

1. IC₁ = HA5024
2. IC₂ = HA5020
3. IC₃ = HFA3102
4. IC₄ = HA5170

FIGURE 1. FOUR ICs AND A HANDFUL OF COMPONENTS PROVIDE 1% ACCURATE PHASE MEASUREMENTS TO 10MHz IN THIS LOW-COST CIRCUIT.

Intersil Corporation reserves the right to make changes in circuit design, software and/or specifications at any time without notice. Accordingly, the reader is cautioned to verify that the Application Note or Technical Brief is current before proceeding.

For information regarding Intersil Corporation and its products, see www.intersil.com